

Cardio Theater xTV863 Receivers

Installation and Maintenance Guide

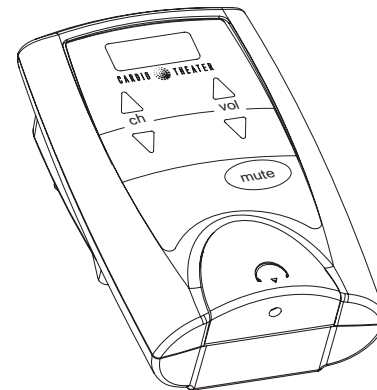
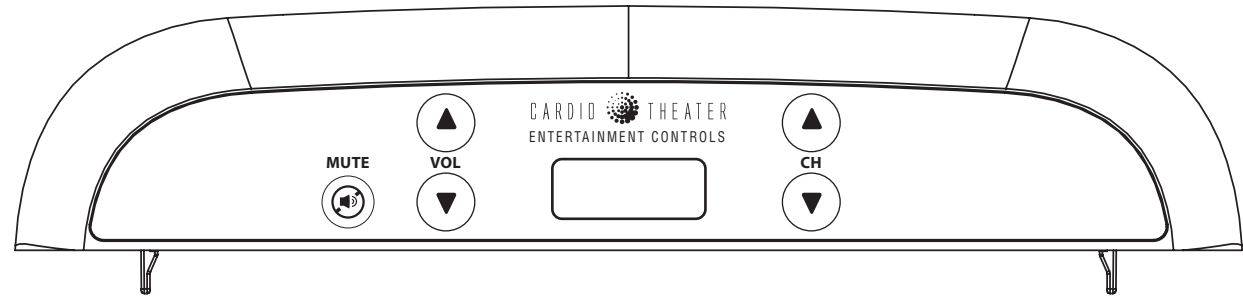

CARDIO  THEATER®

Important Safety Instructions

Always follow basic safety precautions when using this equipment to reduce the chance of injury, fire, or damage.

- Read all instructions in this guide before installing and using the equipment. Follow any labels on the equipment.
- Use the power adapter provided with the equipment. Plug the power adapter into an appropriate, grounded power outlet as marked on the equipment.
- Position power cables so that they are not walked on or pinched by items placed upon or against them.
- Keep the equipment away from water and moisture.
- Locate the equipment away from sources of heat, such as radiators, heat registers, and stoves. Avoid temperature extremes.
- Avoid dropping anything on or spilling anything inside the equipment, because doing so can damage the electronics.
- Do not attempt to service the unit yourself except to follow the maintenance instructions found in this guide.

Regulatory Information

This product is compliant to:

- 89/336/EEC Electromagnetic Compatibility Directive.
- 99/5/EEC Radio and Telecommunications Directive.
- 73/23/EEC Low Voltage Directive.

Table of Contents

Important Safety Instructions	1	Programming Each Receiver	15
Regulatory Information	1	Automatic Programming	15
Before You Begin	3	Manually Programming a Receiver	16
About the xTV863 Receiver	4	Maintenance and Troubleshooting	18
Installation Requirements	4	Cleaning Receivers	18
Obtaining Service	5	Checking Standalone Receivers	18
Install Standalone Receivers on		Troubleshooting the Receiver	18
Exercise Equipment	6	Replacing the Headphone Jack on a	
Unpacking the Equipment	6	Standalone Receiver	19
Required Tools	6	Replacing the Headphone Cover on an	
Suggested Tool	6	Integrated Receiver	20
Installing the Standalone Receiver	7	Limited Warranty	22
Install Integrated Receivers on Display Consoles	9		
Unpacking the Equipment	9		
Required Tools	9		
Installing the Integrated Receiver on an EFX,			
Climber, or Cycle	9		
Installing the Integrated Receiver			
on a Treadmill	11		

Before You Begin

With the Cardio Theater® xTV wireless system, fitness facilities can add entertainment to exercise rooms without the high cabling costs usually associated with entertainment systems. The xTV wireless system gives people the choice of listening to music, radio, or programs shown on TVs while they exercise. The person simply plugs a stereo headphone into the headphone jack, selects the desired entertainment, and exercises while listening to high-fidelity sound.

An xTV wireless system consists of one or more xTV-8T Transmitters, one for each TV and audio component, and a number of xTV863 receivers installed on exercise equipment throughout the room. Cardio Theater offers two different xTV863 receivers: xTV-8RLP Low Power Standalone Receiver and xTV-8RAB Integrated Audio Receiver. See Figure 1. The standalone receiver attaches to the handlebars of almost any exercise equipment, while the other receiver integrates with the latest Precor cardio equipment introduced in 2006. Both receivers allow facilities to offer entertainment to people using a variety of exercise equipment, old and new, from a variety of manufacturers.

This guide explains how to install and maintain both xTV863 receivers. For proper installation, please read this guide thoroughly and follow the instructions.

Note: For information about xTV-8T Transmitters, refer to the *xTV-8T Transmitter Installation and Maintenance Guide*.

xTV-8RLP Low Power Standalone Receiver

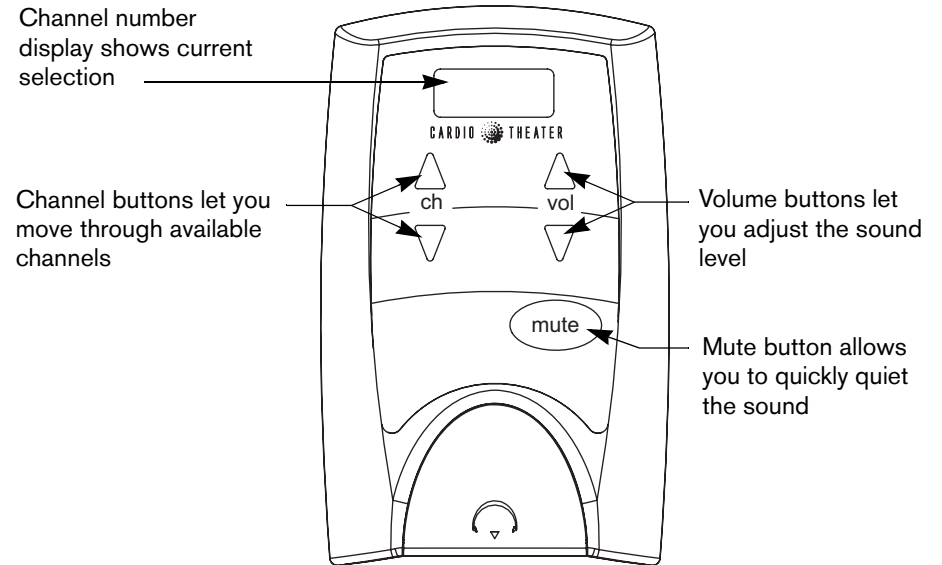

xTV-8RAB Integrated Audio Receiver

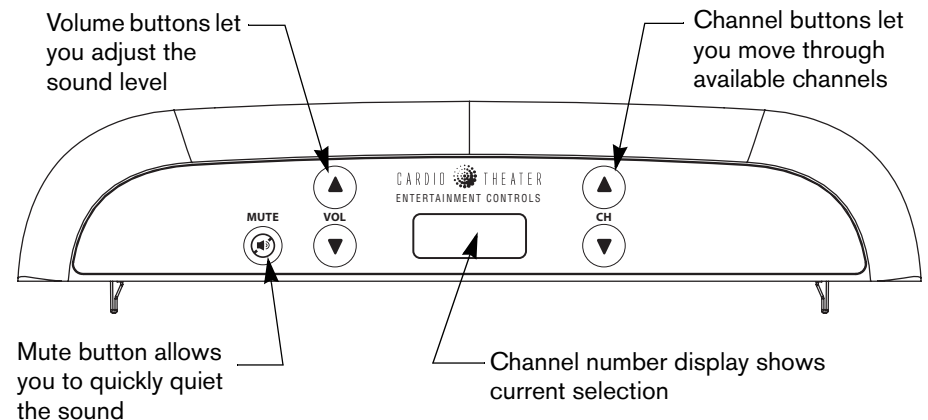

Figure 1: Introduction to standalone and integrated receivers

About the xTV863 Receiver

The xTV863 receiver supports many channels of high-fidelity sound. Use of the receiver is intuitive; people can typically begin using the receiver with little or no training.

During installation, the technician attaches receivers to selected equipment in the facility. Receivers are typically powered by the equipment to which they are attached. For example, when connected to a treadmill, the receiver is powered continuously as long as the treadmill is turned on. With self-powered equipment, such as cycles and elliptical crosstrainers, the receiver turns on when a person is using the equipment, or the optional power adapter is connected to the equipment.

Note: To receive power from exercise equipment, standalone receivers require exercise equipment with CSAFE power connections. Otherwise, the receiver must be powered through an AC power adapter plugged into a power outlet.

Installation Requirements

Review the following installation requirements before assembly:

- Transmitters and receivers should be installed so they are within 50 meters of each other and are in direct line of sight. For example, if you are within 30 meters and can see the transmitter antenna, the receivers should have good reception.
- With new xTV wireless installations, we recommend installing the receivers on the equipment first, then installing the transmitters. Doing so will allow installers to check the sound quality of the transmitters throughout the room.

- Receiver channels are programmed during installation and will correspond to the TV and audio options available. The receiver automatically acquires the available channels from the installed transmitters and assigns them to channel numbers, starting with the lowest transmitting channel to the highest transmitting channel, regardless of which channels are used.
- To avoid confusion with people using the wireless system, you want receivers to logically select TV and audio components based on their placement. So, on the receiver, channel 1 would select the first TV, channel 2 would select the second TV, and so on. To support this logical usage, transmitters need to be installed in channel order, as explained in the *Transmitter Installation and Maintenance Guide*.
- There is no correlation between channel numbers on transmitters and channel numbers shown on receivers when they are programmed. For more information about transmitter channels, refer to the *Transmitter Installation and Maintenance Guide*.

Obtaining Service

Do not attempt to service the Cardio Theater xTV863 Receiver, except as explained in this guide. For information about product operation or service, refer to the Cardio Theater web site at www.cardiotheater.com or contact an authorised dealer. For information about product operation or service, contact an authorised Cardio Theater Technical Support Representative at +44 118 973 9633 or emeaservice@cardiotheater.com.

Returning Equipment to Cardio Theater

To return equipment to Cardio Theater for any reason, you must contact Cardio Theater Technical Support and obtain a Return Authorisation Number (RMA). When requesting the RMA number, explain why you are returning the equipment, for example you ordered too many receivers and the extra receiver can be returned to stock, or the equipment needs repairs.

Important: *Equipment must be shipped with an RMA number in order for Cardio Theater to process it. Any equipment received without an RMA number will be returned to the sender.*

Install Standalone Receivers on Exercise Equipment

This section explains how to install the xTV-8RLP standalone receiver on the handlebars of selected equipment in the facility.

You can attach receivers to the handlebars of almost any exercise equipment. However, for safety, the receiver must be installed on a stationary location, so you cannot install it on handlebars that move.

Attach the receivers securely with the wire ties and neoprene pads. When a receiver is properly attached to a piece of equipment, it should not move. Proper installation is important to prevent moisture from entering the receiver through the power connector and damaging the electronics.

Remember to read and follow the instructions in this guide. If you do not install the xTV-8RLP receivers according to these instructions, you could void the Limited Warranty.

Unpacking the Equipment

The standalone receiver is shipped with the following items:

- One or more xTV-8RLP Receivers as ordered
- Neoprene pad, 1 per receiver
- Wire ties, 4 per receiver
- CSAFE power cable or AC power adapter kit for your country, 1 per receiver (see Note below)
- These installation instructions

Note: The choice of a CSAFE power cable or AC power adapter kit for a receiver is determined when the wireless equipment is ordered. If a piece of exercise equipment is CSAFE compatible, you should use a CSAFE power cable to power the receiver to simplify installation.

If any items are missing, contact the dealer from whom you purchased the unit or contact Cardio Theater Technical Support.

Required Tools

Obtain these tools before assembly:

- Tool to cut the wire ties
- Pliers to tighten the wire ties

Suggested Tool

You may want to add the optional power adapters to the self-powered equipment in your facility. To purchase the optional power adapters, check with your Precor dealer.

Installing the Standalone Receiver

1. Identify the equipment on which you plan to attach the receivers.

You can attach receivers to almost any exercise equipment.

2. Determine where on the equipment you will install each receiver. When you choose a location for the receiver, make sure that the person can comfortably reach it and that its controls are easily readable. Also, make sure that the receiver does not interfere with the equipment's display console or moving parts.

You can attach a receiver either horizontally or vertically. You cannot attach a receiver to handlebars that move.

3. Connect the power cable into the RJ45 connector on the back of the receiver. Push the rubber boot firmly into the recess around the connector to ensure a tight seal. See Figure 2.

Important: Make sure that the rubber boot securely covers the connector to prevent moisture damage, or you could void the Limited Warranty.

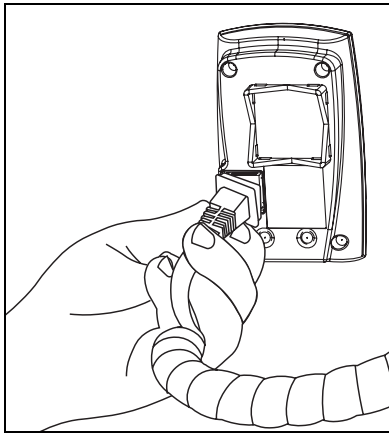

Figure 2: Back of receiver showing rubber boot being properly installed

4. Attach the neoprene mounting pad to the desired location on the handlebar. See Figure 3.

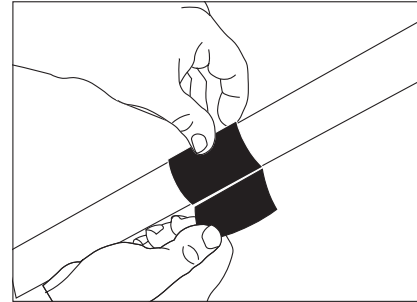

Figure 3: Install the mounting pad to the handlebar

5. Insert two wire ties through the holes in the mounting bracket on the back of the receiver.
6. Place the receiver on the neoprene mounting pad, and then attach it to the handlebar using the wire ties. See Figure 4. Use the pliers to tighten the wire ties so the receiver cannot move.

Important: Be sure to secure the receiver on the handlebar so that it cannot move. If the receiver moves, it may damage the exercise equipment as well as itself, and void the Limited Warranty.

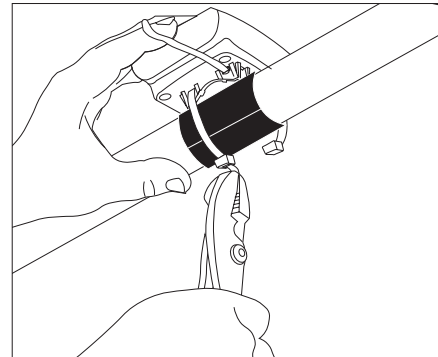

Figure 4: Install the receiver on the handlebar with wire ties

7. Cut off the excess plastic from the wire ties, being careful not to leave any sharp edges on the wire ties.
8. Plug the other end of the power cable into a power outlet or, if the equipment is Cardio Theater ready, the CSAFE power connector.

The receiver will be powered by either an AC power adapter plugged into a power outlet or a CSAFE power cable connected to the exercise equipment. Only exercise equipment that is Cardio Theater ready can use CSAFE power cables; you may need different power cables for different types of exercise equipment. If you have any questions about powering your receivers, contact Cardio Theater Technical Support.

9. Repeat the above steps for each standalone receiver that you plan to install.

Install Integrated Receivers on Display Consoles

This section explains how to install the xTV-8RAB integrated receiver on a Precor cardio equipment console. You can also follow these instructions to replace an existing integrated receiver. The instructions differ depending on the type of equipment on which you are installing. Choose the appropriate instructions based on your situation.

Remember to read and follow the instructions in this guide. If you do not install the xTV-8RAB receivers according to these instructions, you could void the Limited Warranty.

Important: Wear a static guard on your wrist to safeguard against static electricity damage to the electronic equipment housed in the Cardio Theater and Precor units.

Unpacking the Equipment

The integrated receiver is shipped with the following items:

- One or more xTV-8RAB receivers as ordered
- Headphone jack cover, 1 per receiver
- These instructions

If any items are missing, contact the dealer from which you purchased the unit or contact Cardio Theater Technical Support.

Required Tools

Obtain these tools before assembly:

- Crosshead screwdriver
- (Treadmill installation only) Flathead screwdriver

Installing the Integrated Receiver on an EFX, Climber, or Cycle

1. Use a crosshead screwdriver to remove the four screws that secure the back console plate. Set the screws and back console plate aside.

If you are installing the integrated receiver on a climber, you will also need to remove the one screw that secures the neck cover. Set the neck cover and screw aside.

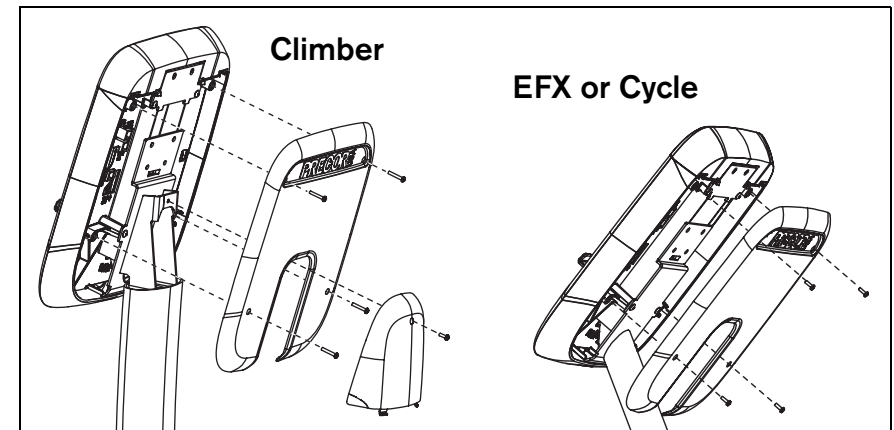

Figure 5: Remove back console plate

2. Remove the entertainment option cover. See Figure 6. Tabs exist on either side of the cover. Press in on the tabs and the cover pops off. You can discard the entertainment option cover.

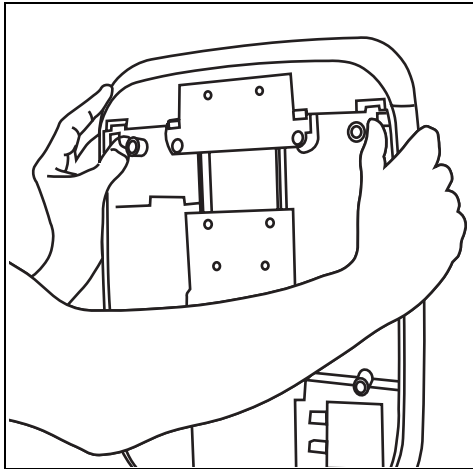

Figure 6: Remove entertainment option cover

Important: If you are replacing the integrated receiver, disconnect the 5-wire cable from the display console, and then pull the stereo plug (audio cable) out of the cover before removing the receiver.

3. At the base of the display console, remove the audio cover. Place a finger inside the audio cover to push it out of the display console. You can discard the audio cover because it is replaced with the headphone jack.
4. Separate the display console face from the console. See Figure 7. Start at the top and work toward the bottom by pressing in on five of the tabs that secure it. This provides easier access to the 5-pin connector.

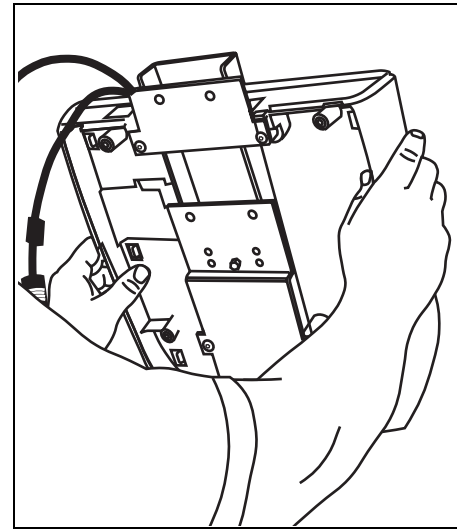

Figure 7: Separate display console face

5. Hold the integrated receiver above the display console and feed the audio cable through the opening in the base of the display console. Let the audio cable hang loose.

CAUTION: It is critical that you attach the red wire on the 5-wire entertainment option cable to Pin 1. The word, PIN 1, is inscribed on the back of the display console. An arrow points to the location of Pin 1. The connector is keyed so it will only connect one way. Do not force the connection.

6. Connect the 5-wire entertainment option cable to the display console.
7. Reattach the display console face by aligning the tabs and applying pressure to the display face.
8. Install the integrated receiver by aligning the two tabs and applying pressure. Arrange the cables so when you reattach the cover, you do not inadvertently pinch or damage the cables.

Important: Cable damaged by improper installation will not be covered by the Limited Warranty.

9. Feed the audio cable through the base of the display console and attach it to the headphone jack. See Figure 8.

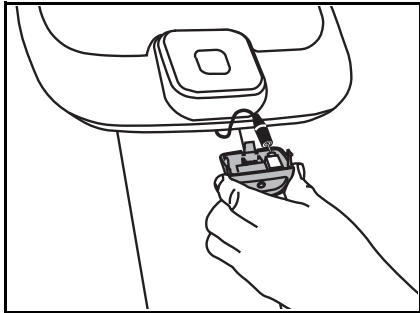

Figure 8: Attach audio cable to headphone jack

10. Insert the headphone jack into the base of the display console. Snap the headphone jack into place by positioning the rear tab first, and then applying pressure to the base. See Figure 9.

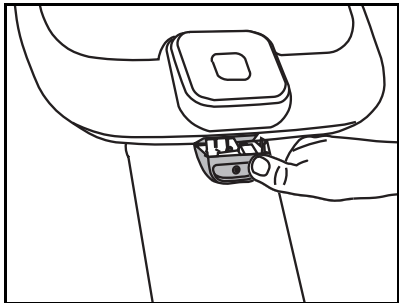

Figure 9: Snap headphone jack into place

11. Use a crosshead screwdriver to replace the back console plate with the four screws removed in step 1. If you also removed the neck cover (climber installation only), reinstall the neck cover with the one screw.

Installing the Integrated Receiver on a Treadmill

1. Turn OFF the Precor treadmill and unplug it. The ON/OFF (I/O) switch is located on the front of the treadmill beneath the hood overhang.
2. Unplug any RJ45 connections from the back of the display console cover before removing the cover.
3. Use a crosshead screwdriver to remove the nine screws that secure the display console back cover. See Figure 10. Set the fasteners aside.

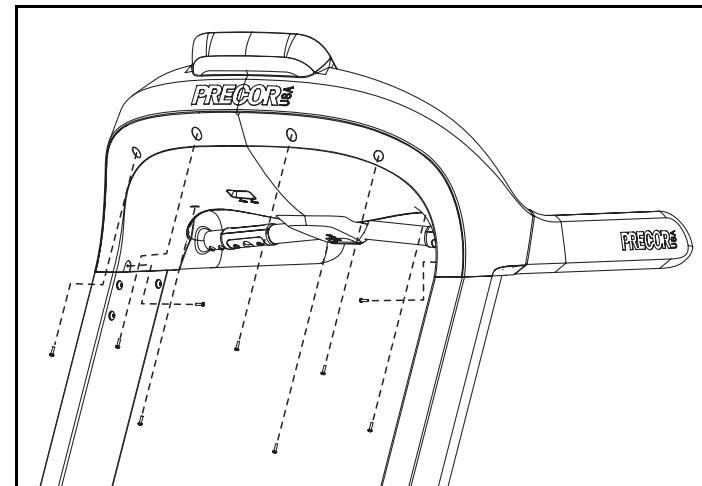

Figure 10: Remove display console back cover screws

4. To remove the display console back cover, pull in on one side as you pull the cover down toward the floor. This should flex the cover and enable you to slide it past the fasteners on the upright support. See Figure 11.

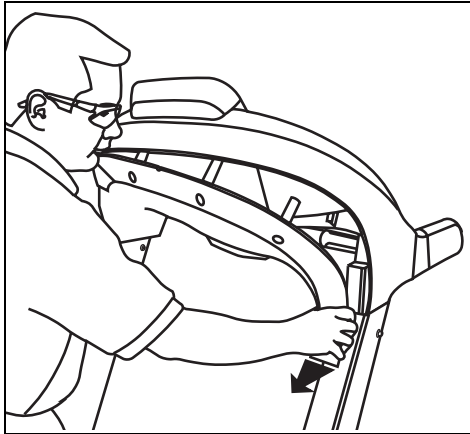

Figure 11: Remove display console back cover

5. Remove the entertainment option cover. See Figure 12. Tabs exist on either side of the cover. Press in on the tabs and the cover pops off. You can discard the entertainment option cover.

Important: If you are replacing the integrated receiver, disconnect the 5-wire cable from the display console, and then pull the stereo plug (audio cable) out of the cover before removing and discarding the cover.

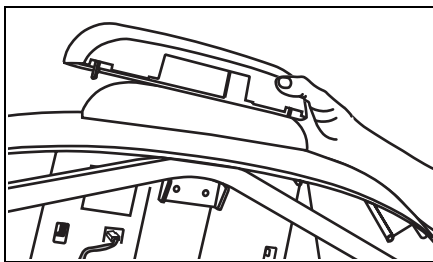

Figure 12: Remove entertainment option cover

6. At the base of the display console back cover, remove the break away piece to allow room for the audio cable. Use a flathead screwdriver to push the piece out of the display console back cover. See Figure 13. You can discard the break away piece.

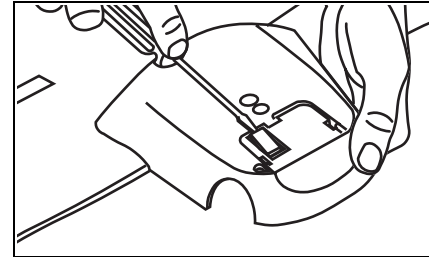

Figure 13: Remove break away piece with screwdriver

7. Separate the display console face from the console. See Figure 14. Start at the top and work toward the bottom by pressing in on five of the tabs that secure it. This provides easier access to the 5-pin connector.

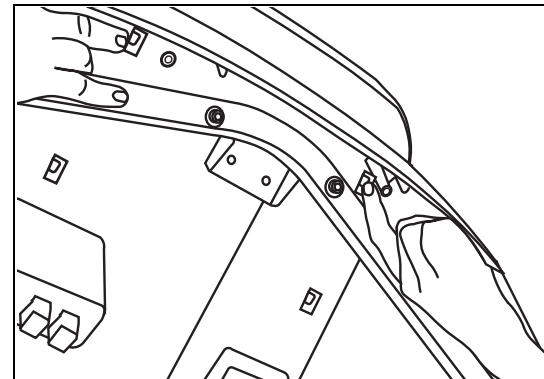

Figure 14: Separate display console face from console

8. Hold the integrated receiver above the display console, and feed the stereo plug (audio cable) through the opening in the base of the display console. Let the audio cable hang loose. See Figure 15.

CAUTION: It is critical that you attach the red wire on the 5-wire entertainment option cable to Pin 1. The word, PIN 1, is inscribed on the back of the display console. An arrow points to the location of Pin 1. The connector is keyed so it will only connect one way. Do not force the connection.

9. Connect the 5-wire entertainment option cable to the display console. See Figure 15.

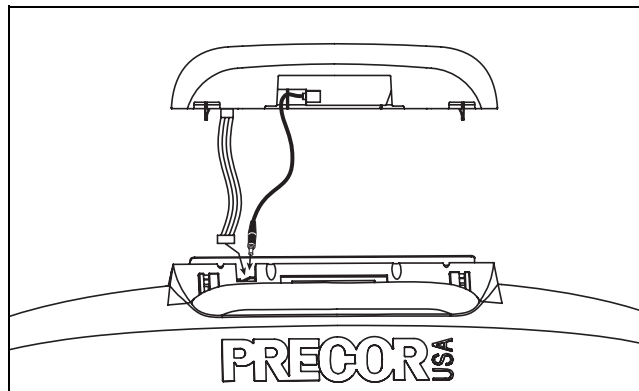

Figure 15: Feed cables through the entertainment option cover

10. Reattach the display console face by aligning the tabs and applying pressure to the display face.
11. Install the integrated receiver by aligning the two tabs and applying pressure. Arrange the cables so you do not inadvertently pinch or damage the cables.

Important: Cable damaged by improper installation will not be covered by the Limited Warranty.

12. Feed the audio cable through the break out in the display console cover.

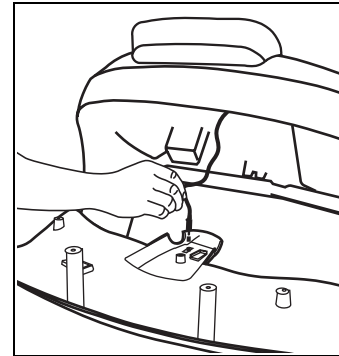

Figure 16: Feed audio cable through display console cover

13. Replace the display console back cover by positioning one side above the upright support fasteners. Pull in on the other side to flex the cover which allows you to push it up and slide it past the fasteners on the upright support. See Figure 17.

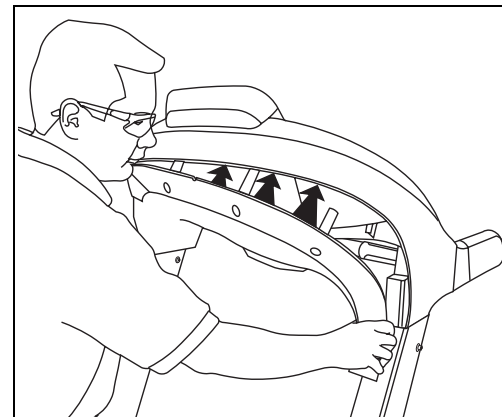

Figure 17: Replace display console back cover

14. Use a flat head screwdriver to slide the display console cover under the top console cover.

15. Use a crosshead screwdriver to reattach the display console back cover with the nine fasteners removed in step 3.

16. Attach the stereo plug to the headphone jack.

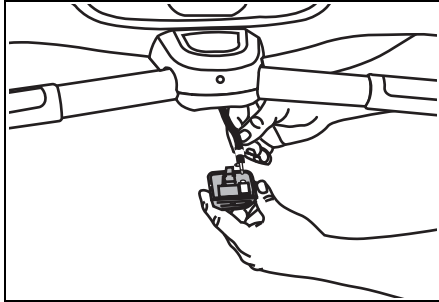

Figure 18: Attach stereo plug

17. Insert the headphone jack into the base of the display console. Snap the headphone jack into place by positioning the rear tab first, and then applying pressure to the base.

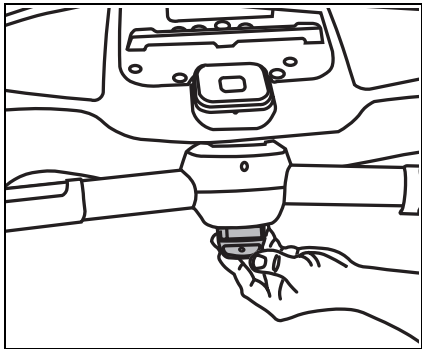

Figure 19: Snap headphone jack into place

Programming Each Receiver

This section explains how to use the automatic programming process to set up xTV863 receivers. During automatic programming, the receiver acquires the available channels from the installed transmitters, and assigns them to channel numbers. You will need to follow this process for each new receiver, or when a receiver is replaced.

After automatic programming, a receiver may be missing some channels or the programming is incorrect. You will find a section that explains how to manually program a receiver to add or remove channels as needed.

You can follow the instructions in this section for both the standalone and integrated receivers.

Automatic Programming

1. Make sure all transmitters are properly installed and plugged in.
Important: Transmitters must not share the same channel, because it will cause a problem for the automatic programming feature of the receivers and affect the performance of the wireless system.
2. Power up the receiver. If it is connected to self-powered exercise equipment, you or an assistant will need to use the equipment. The optional power adapter is a useful tool for self-powered equipment.
3. Begin the automatic programming process on a receiver by pressing the Channel ▲ and Mute buttons simultaneously for 3 seconds.
4. When the display shows “AP”, release the buttons. The display then shows a number from “-1” to “-3,” which indicates its program mode.

Table 1: Receiver programming modes

<i>Display Number</i>	<i>xTV Program Mode Description</i>
-1	12 frequencies
-2	8 frequencies (Recommended mode)
-3	10 frequencies

5. If necessary, use the Channel ▲ and ▼ buttons to select the appropriate program mode. Most facilities use xTV program mode -1.
6. Press the Mute button to select the program mode. The receiver starts the automatic programming sequence, scanning the active transmitter channels and storing them in memory. When the sequence is finished, the receiver restarts and the first available channel appears on the display.

Once automatic programming has completed, you should confirm that the receiver has picked up all the available channels. Automatic programming can be affected by a number of factors, including outside interference. This may cause the receiver to miss some channels or program unwanted channels.

7. Check that the receiver can clearly receive the available channels by selecting, then listening to each channel programmed.

As you move through the channels on the receiver, be aware that the receiver orders transmitter channels from the lowest to the highest, then assigns each to a channel, starting with channel 1.

8. If you find the receiver is missing some channels or the programming is incorrect, manually program the receiver, as explained in the next section. Skip to step 8 of that section.
9. Repeat steps 2 through 8 for each receiver that will be installed.

Manually Programming a Receiver

The receiver automatically searches the area for available channels during automatic programming. Sometimes, however, the automatic programming feature does not pick up all the transmitted channels, or it erroneously programs unwanted channels. You can manually program the receiver to add or remove channels and solve these problems. *You must run automatic programming before you can run manual programming.*

When you enter manual programming, the receiver will display the transmitter channel numbers it has found. For example, an installation has five xTV-8T Transmitters, assigned channel numbers 2, 6, 7, 10, and 11 and installed in that order from left to right. The receiver has found these transmitted channels and assigned them to a sequence of channel numbers that it displays as 1 through 5. See Table 2.

Table 2: Example during manual programming

<i>Transmitter Channel</i>	<i>Receiver Shows in Manual Programming</i>	<i>Receiver Assigns to Number that People Use to Select Component</i>
1	Flashing number, not programmed	
2	Solid number	1
3	Flashing number, not programmed	
4	Flashing number, not programmed	
5	Flashing number, not programmed	
6	Solid number	2
7	Solid number	3
8	Flashing number, not programmed	
9	Flashing number	
10	Solid number	4
11	Solid number	5
12	Flashing number	

1. If you have already run automatic programming, as described in the previous section, skip to step 8.
2. Make sure all transmitters are properly installed and plugged in.
3. Power up the receiver. If it is connected to self-powered exercise equipment, you or an assistant will need to use the equipment. The optional power adapter is a useful tool for self-powered equipment.
4. At the receiver, press the Channel ▲ and Mute buttons simultaneously for 3 seconds.
5. When the display shows “AP”, release the buttons. The display then shows a number from “-1” to “-3,” which indicates its program mode.

6. If necessary, use the Channel ▲ and ▼ buttons to select the appropriate program mode for your site. Refer to Table 1 earlier for a list of program modes. Most facilities use -1 Cardio Theater xTV program mode.
7. Press the Mute button to select the program mode and start automatic programming. During this process the receiver scans the active transmitter channels and stores them in memory. You must run automatic programming before you can run manual programming.
8. Start manual programming by pressing the Channel ▼ and Mute buttons simultaneously for 3 seconds.
9. When the “-P” appears on the display, release both buttons. Channel number 1 appears on the display.
10. Use the Channel ▲ and ▼ buttons to scroll through the transmitted channels that the receiver has acquired.
11. For each channel, determine if you want to change its status. Pressing the Mute button switches states for a channel:
 - A *flashing* number indicates a channel that is inactive.
 - A *solid* number indicates a channel that is active.
12. When you have reviewed and programmed the channels, press both Channel buttons simultaneously for 3 seconds to save your changes and exit programming mode.
13. Check that the receiver can clearly receive the available channels by selecting, then listening to each channel programmed.

Maintenance and Troubleshooting

In general, receivers require little maintenance beyond regular cleaning and periodic checks of their installations and connectors. Refer below for maintenance information.

Receivers rarely experience problems once the wireless system is installed. However, you may find the troubleshooting information in this section useful for solving the odd problem.

If necessary, this section also explains how to replace the headphone jack when a receiver no longer provides good sound quality.

Cleaning Receivers

Each week, clean the receivers with a mild soap and water solution. Lightly dampen a soft cloth with the solution and wipe the receiver. Do not use too much solution on the cloth or spray cleaning solution directly on receivers. Doing so could cause moisture to enter through the connector and damage the receiver.

Checking Standalone Receivers

Make sure that each standalone receiver is secure and cannot be moved. Also ensure that the receiver is positioned so that moisture from people exercising cannot enter through the connection and damage the electronics.

Make sure that the rubber boot around the RJ45 connector is properly positioned. Push the rubber boot firmly into the recess around the connector to ensure a tight seal. See Figure 2 earlier if needed.

Troubleshooting the Receiver

Table 3 may help you to understand and troubleshoot any problems that you encounter with the receiver. If the suggestions in the table do not help you solve the problems that you encounter, contact Cardio Theater Technical Support.

Table 3: How to solve most problems with receivers

<i>Problem</i>		<i>What to Do</i>
Static interference on a channel	Single receiver	Try reprogramming receiver. Change location of transmitter; you may find something is hampering the sound. Replace headphone jack. Replace receiver.
	All receivers	Sound on TV or audio component may be too high. Check the equipment and lower the volume level if needed. May be a problem with transmitter; see <i>Maintenance and Troubleshooting</i> in transmitter guide.
Noisy sound on a channel	Single receiver	Try reprogramming receiver. Check location of receiver; you may find that it is too far from the transmitter. Replace headphone jack. Replace receiver.
	All receivers	Most likely problem with transmitter; see <i>Maintenance and Troubleshooting</i> in transmitter guide.

Problem		What to Do
No sound on a channel	Single receiver	Make sure the display is on; the power cable may be disconnected. Try unmuting the receiver. Try turning up the volume. Replace headphone jack. Replace receiver.
	All receivers	Sound on TV or audio component may be off or muted. Check the volume on the equipment and increase the volume or unmute as needed. May be a problem with transmitter; see <i>Maintenance and Troubleshooting</i> in transmitter guide.
Receiver channels do not match the order of the TV and audio components; for example, channel 1 selects the second TV and channel 2 selects the first TV.		Transmitters were not installed in channel order. Receivers automatically assign transmitter channels to receiver channels, from lowest to highest (see Table 2). Move or reprogram transmitters so channel numbers are in a logical sequence. You will need to reprogram receivers as well.
Receiver does not keep programming or the display shows an error.		Moisture may have corroded the electronics inside; replace the receiver.

Replacing the Headphone Jack on a Standalone Receiver

When someone using a receiver experiences no sound or poor sound quality (such as intermittent sound or crackling), you should check the headphone jack. Try moving the headphone plug in the headphone jack. If the problem continues, the jack should be replaced.

The standalone receiver is designed to make changing the headphone jack a quick and easy job, one easily done at the facility. You will need a crosshead screwdriver to replace the headphone jack. If you need to remove the receiver from its location to access the screws, you will also need two new wire ties to reattach the receiver, pliers, and a tool to cut the old wire ties.

You do not need to disconnect the power cable from the receiver to perform this procedure.

1. Determine whether or not you need to remove the receiver from its location to access the two screws on the back that hold the headphone jack.
2. If needed, cut the two wire ties holding the receiver to the equipment. Remove the wire ties from the receiver and toss.
3. Remove the two screws at the bottom of the receiver with a crosshead screwdriver. See Figure 20.

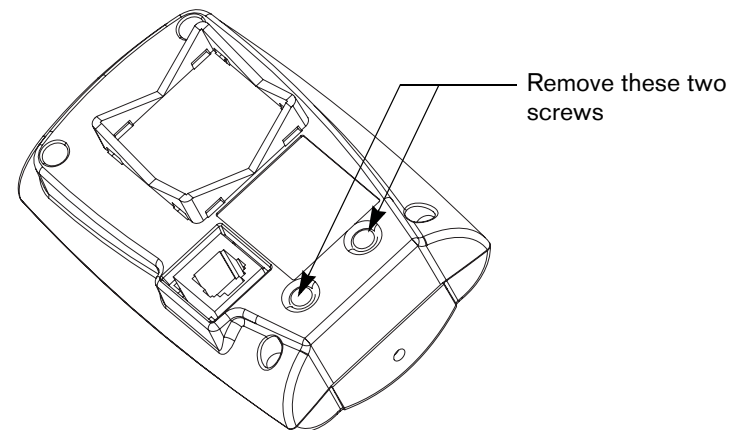

Figure 20: Remove screws holding headphone jack

4. Remove the headphone jack.
5. Insert a new headphone jack. Insert the two screws and tighten.
6. If needed to re-attach the receiver, insert two wire ties through the holes in the mounting bracket on the back of the receiver.
7. If needed, place the receiver on the neoprene mounting pad, and then attach it to the equipment with the wire ties. Use the pliers to tighten the wire ties so the receiver cannot move.

Important: Be sure to secure the receiver on the handlebar so that it cannot move. If the receiver moves, it may damage the exercise equipment as well as itself, and void the Limited Warranty.

8. If you re-attached the receiver, cut off the excess plastic from the wire ties, being careful not to leave any sharp edges on the wire ties.
9. Check the rubber boot over the RJ45 connector to make sure it covers the connector with a tight seal.

Replacing the Headphone Cover on an Integrated Receiver

When someone experiences no audio or poor audio quality (such as intermittent audio or crackling), you should check the headphone jack. The headphone jack is designed to be easily and quickly replaced at the facility. Make sure you have a new headphone jack (CX30315) before you begin.

1. Firmly grasp the headphone jack, located under the display console. With one hand squeeze the sides near the top while pulling down with your thumb using your other hand. See Figure 2. You may find it helpful to wiggle the jack from side to side. The headphone jack should pop off the display console, with the audio cable still connected.

The headphone jack has two tabs on each side and one tab in the back. These tabs help to secure the headphone jack to the console.

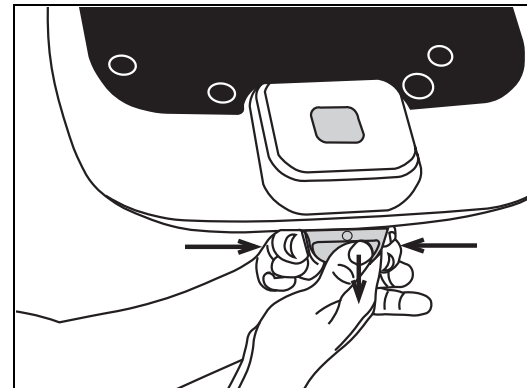

Figure 21: Grasp the headphone jack and remove it from the console

2. Disconnect the audio cable. You can discard the used headphone jack.

3. Slide the stereo plug on the audio cable into the new headphone jack.
4. Replace the headphone jack into place under the display console. Line up the back tab with the back slot, feed the audio cable inside the console, and then snap the two side tabs into the two side slots.

Important: Do not stretch, crimp, or damage the cable. Cables damaged by improper installation will not be covered by the Limited Warranty.

Limited Warranty

PLEASE READ THESE WARRANTY TERMS AND CONDITIONS CAREFULLY BEFORE USING YOUR CARDIO THEATER PRODUCT. BY USING THE EQUIPMENT, YOU ARE CONSENTING TO BE BOUND BY THE FOLLOWING WARRANTY TERMS AND CONDITIONS.

Limited Warranty.

Precor Incorporated ("Precor") warrants all new Cardio Theater products to be free from defects in materials and manufacture for the warranty periods set forth below. The warranty periods commence on the invoice date of the original purchase. This warranty applies only against defects discovered within the warranty period and extends only to the original purchaser of the product. Parts repaired or replaced under the terms of this warranty will be warranted for the remainder of the original warranty period only. To claim under this warranty, the buyer must notify Precor or your authorized Cardio Theater dealer within 30 days after the date of discovery of any nonconformity and make the affected product available for inspection by Precor or its service representative. Cardio Theater product deemed defective by a Cardio Theater representative, will be issued a return authorization number. **Precor will not accept returns without a return authorization number.** Precor reserves the right, at their option, to repair or replace the product after verification of defect. Product that fails after the warranty period expires will be repaired or replaced at the current part and labor pricing after authorization from the customer. Repairs are warranted for 90 days.

Precor's obligations under this warranty are limited as set forth below.

Warranty Periods and Coverage.

• Cardio Theater Transmitters <i>xTV-T Wireless or Wired Floor Models xTVFM system transmitter</i>	3 Years	Parts & Labor
• Cardio Theater Receivers <i>XTV-R Wireless or Wired Upper Models XTVFM system receiver</i>	1 Year	Parts & Labor
• Cardio Theater LCD Screen (PVS)	1 Year	Parts & Labor
• Cardio Theater Screen Controllers	1 Year	Parts & Labor
• Quick Change Headphone Jack	90 Day	Parts Only
• Optional DVD Player	1 Year	Parts
• CT Experience Series Screen (PVS12)	2 Years	Parts & Labor
• CT Experience Series Screen Controller	2 Years	Parts & Labor
• CT Experience Series 900 & 863 Receiver	2 Years	Parts & Labor
• CT Experience Series Quick Change Headphone Jack	90 Days	Parts Only

Conditions and Restrictions.

This warranty is valid only in accordance with the conditions set forth below:

1. The warranty applies to the Cardio Theater product only while
 - a. it remains in the possession of the original purchaser and proof of purchase is demonstrated,
 - b. it has not been subjected to accident, misuse, abuse, improper service, or mechanical, electrical or non-Precor modification.
 - c. claims are made within the warranty period.
2. This warranty does not cover damage or product failure caused by electrical wiring not in compliance with electrical codes or Precor owner's manual specifications, or failure to provide reasonable and necessary maintenance as outlined in the owner's manual.
This warranty excludes misuse or failures of, for example, poor quality CD's, multiple discs inserted in the player, failures caused by home-produced copies of discs, etc.
3. Except in Canada, Precor does not pay labor outside the United States.
4. Warranties outside the United States and Canada may vary. Please contact your local Dealer for details.

This Limited Warranty shall not apply to:

1. Software (PROM) version upgrades.
2. Normal wear and tear, consumables and cosmetic items, including, but not limited to the following: labels.
3. Repairs performed on Cardio Theater products missing a serial number or with a serial tag that has been altered or defaced.
4. Service calls to correct installation of the product or instruct owners on how to use the product.
5. Pickup and delivery involved with repairs.
6. Any labor costs incurred beyond the applicable labor warranty period.
7. The user is cautioned that changes or modifications not expressly approved by the manufacturer of the product could void the user's authority to operate the product.

Disclaimer and Release.

The warranties provided herein are the exclusive warranties given by Precor and supersede any prior, contrary or additional representations, whether oral or written. ANY IMPLIED WARRANTIES, INCLUDING THE WARRANTY OF MERCHANTABILITY OR FITNESS FOR A PARTICULAR PURPOSE THAT APPLY TO ANY PARTS DESCRIBED ABOVE ARE LIMITED IN DURATION TO THE PERIODS OF EXPRESS WARRANTIES GIVEN ABOVE FOR THOSE SAME PARTS. PRECOR HEREBY DISCLAIMS AND EXCLUDES THOSE WARRANTIES THEREAFTER. Some States do not allow limitations on how long an implied warranty lasts, so the above limitation may not apply to you. PRECOR ALSO HEREBY DISCLAIMS AND EXCLUDES ALL OTHER OBLIGATIONS OR LIABILITIES, EXPRESS OR IMPLIED, ARISING BY LAW OR OTHERWISE, WITH RESPECT TO ANY NONCONFORMANCE OR DEFECT IN ANY PRODUCT, INCLUDING BUT NOT LIMITED TO: (A) ANY OBLIGATION, LIABILITY, RIGHT, CLAIM OR REMEDY IN TORT, WHETHER OR NOT ARISING FROM THE NEGLIGENCE OF PRECOR OR ITS SUPPLIERS (WHETHER ACTIVE, PASSIVE OR IMPUTED); AND (B) ANY OBLIGATION, LIABILITY, RIGHT, CLAIM OR REMEDY FOR LOSS OF OR DAMAGE TO ANY PRODUCT. This disclaimer and release shall apply even if the express warranty set forth above fails of its essential purpose.

Exclusive Remedies.

For any product described above that fails to conform to its warranty, Precor will provide, at their option, one of the following: (1) repair; (2) replacement; or (3) refund of the purchase price. Limited Warranty service may be obtained by contacting the authorized dealer from whom you purchased the item. Precor compensates Servicicers for warranty trips within their normal service area to repair commercial product at the customer's location. You may be charged a trip charge outside the service area. THESE SHALL BE THE SOLE AND EXCLUSIVE REMEDIES OF THE BUYER FOR ANY BREACH OF WARRANTY.

EXCLUSION OF CONSEQUENTIAL AND INCIDENTAL DAMAGES.

PRECOR AND/OR ITS SUPPLIERS SHALL HAVE NO OBLIGATION OR LIABILITY, WHETHER ARISING IN CONTRACT (INCLUDING WARRANTY), TORT (INCLUDING ACTIVE, PASSIVE, OR IMPUTED NEGLIGENCE AND STRICT LIABILITY), OR OTHERWISE, FOR DAMAGE TO THE PRODUCT, PROPERTY DAMAGE, LOSS OF USE, REVENUE OR PROFIT, COST OF CAPITAL, COST OF SUBSTITUTE PRODUCT, ADDITIONAL COSTS INCURRED BY BUYER (BY WAY OF CORRECTION OR OTHERWISE) OR ANY OTHER INCIDENTAL, SPECIAL, INDIRECT, OR CONSEQUENTIAL DAMAGES, WHETHER RESULTING FROM NONDELIVERY OR FROM THE USE, MISUSE OR INABILITY TO USE THE PRODUCT. This exclusion applies even if the above warranty fails of its essential purposes and regardless of whether such damages are sought for breach of warranty, breach of contract, negligence, or strict liability in tort or under any other legal theory. Some states do not allow the exclusion or limitation of incidental or consequential damages, so the above limitation may not apply to you. This warranty gives you specific legal rights, and you may also have other rights, which vary from state to state.

Complete this portion and keep for your records.

Purchased From: _____
(Dealer or store name)

Phone Number: _____
(Dealer or store telephone number)

Product/Model: _____
(For example: Transmitters, Receivers)

Serial Number: _____
(The serial number is found on the shipping container or item.)

Effective 30 June 2006
P/N CX30037-102

Notes:



A Division of Precor Incorporated
20031 142nd Ave NE
Woodinville, WA USA 98072-4002

Cardio Theater is a registered trademark, and Cardio Theater PVS and Cardio Theater Quick Change Headphone Jack are trademarks of Precor Incorporated.
www.cardiotheater.com

NOTICE:

Due to continuing advancements in technology, Precor Incorporated reserves the right to make changes in hardware, packaging, and any accompanying documentation without prior written notice.

xTV863R IMG CX30402-102
Warranty Statement CX30037-102
01 August 2006